



# SZABO SCANDIC

Part of Europa Biosite

## Produktinformation



Forschungsprodukte & Biochemikalien



Zellkultur & Verbrauchsmaterial



Diagnostik & molekulare Diagnostik



Laborgeräte & Service

Weitere Information auf den folgenden Seiten!  
See the following pages for more information!



### Lieferung & Zahlungsart

siehe unsere [Liefer- und Versandbedingungen](#)

### Zuschläge

- Mindermengenzuschlag
- Trockeneiszuschlag
- Gefahrgutzuschlag
- Expressversand

### SZABO-SCANDIC HandelsgmbH

Quellenstraße 110, A-1100 Wien

T. +43(0)1 489 3961-0

F. +43(0)1 489 3961-7

[mail@szabo-scandic.com](mailto:mail@szabo-scandic.com)

[www.szabo-scandic.com](http://www.szabo-scandic.com)

[linkedin.com/company/szaboscandic](https://www.linkedin.com/company/szaboscandic) 

# Corning® Step-R™ Repeating Pipettor



## Quick Start Guide

Catalog Numbers 4217 and 6636

### 1. Operating Elements

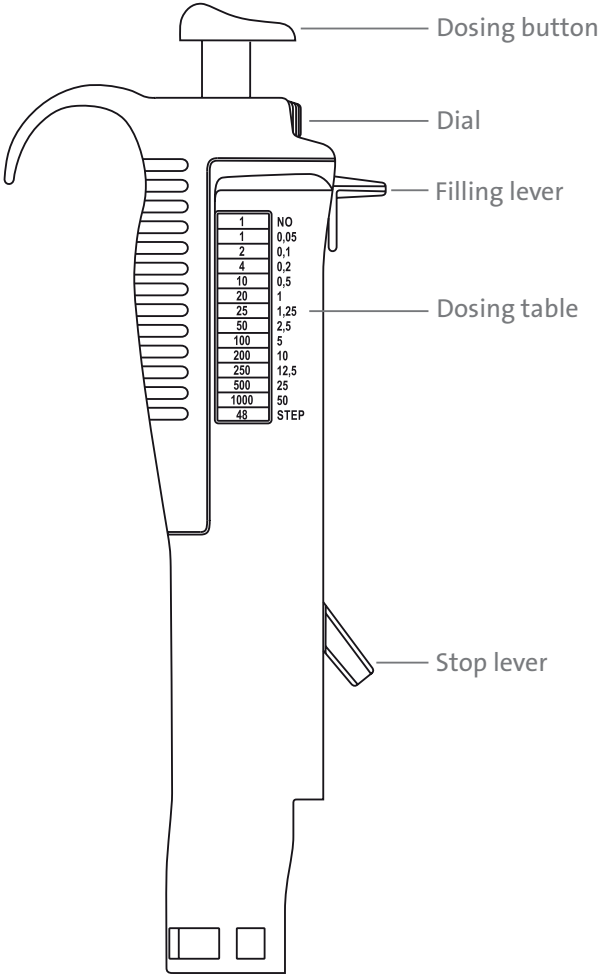

## 2. Inserting the Syringe Tip

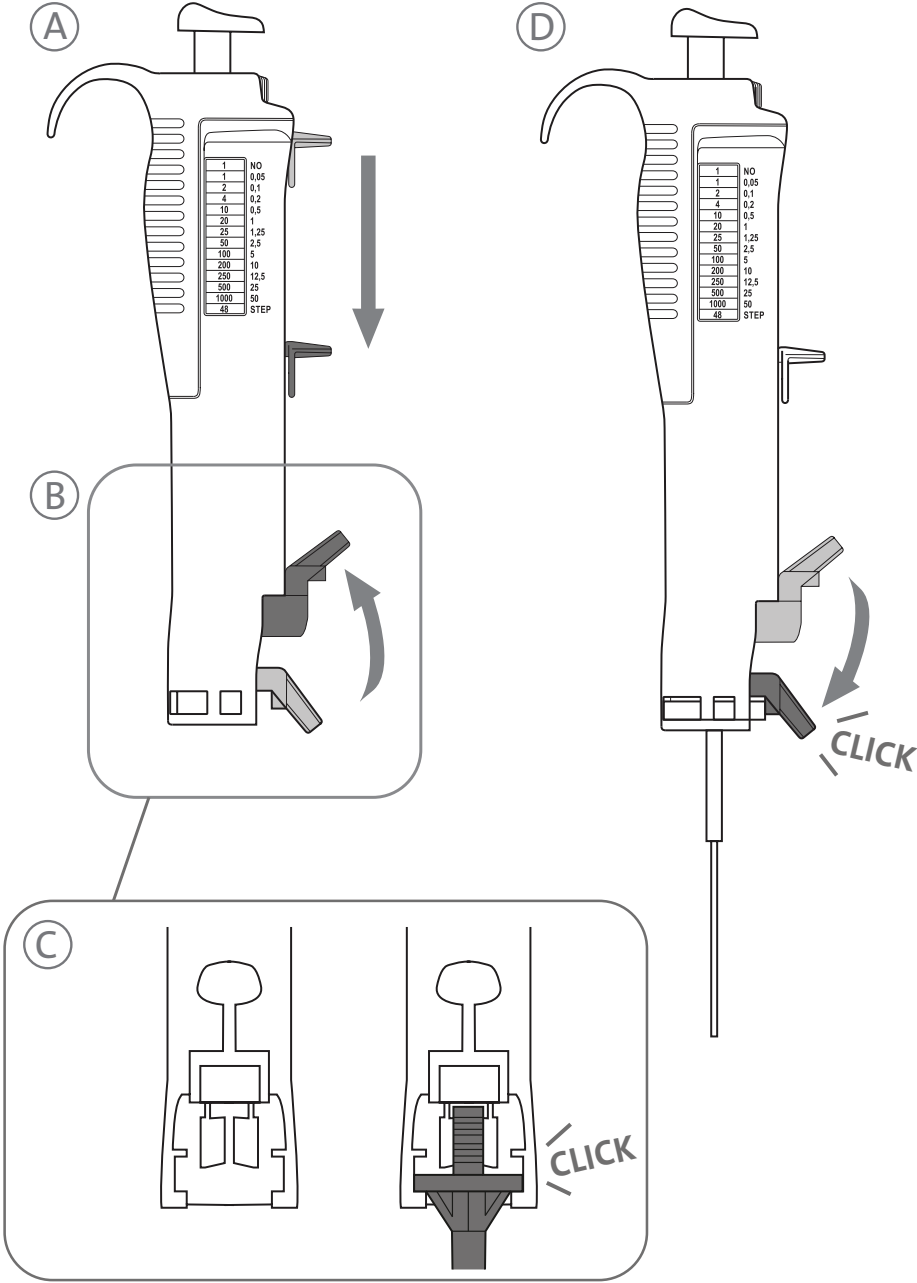

### 3. Adapter (25 mL and 50 mL syringe tips only)

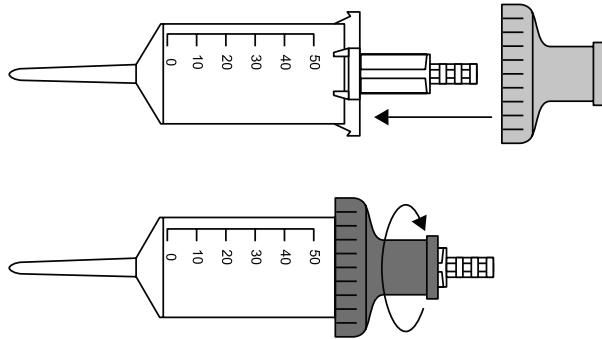

### 4. Filling the Syringe Tip

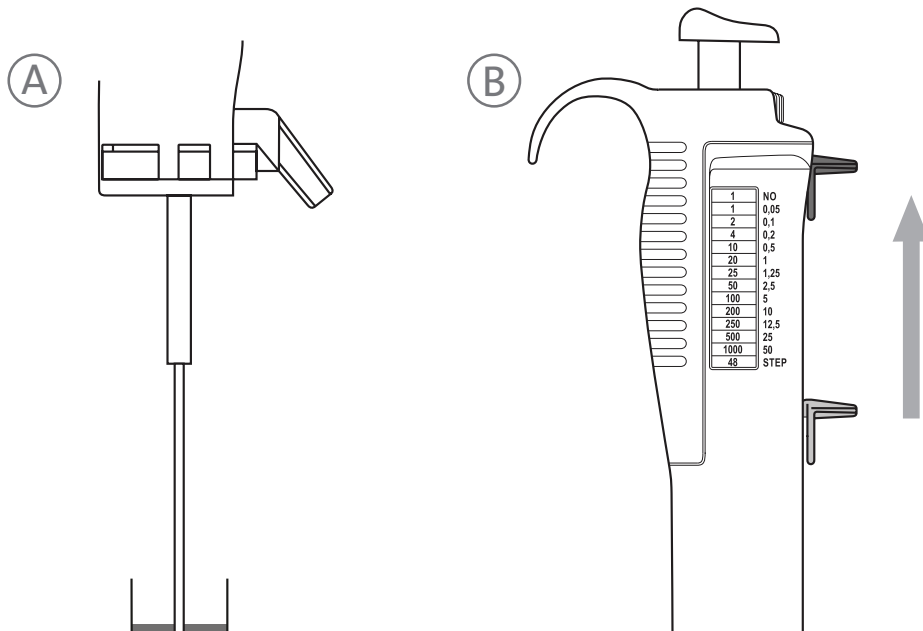

## 5. Volume Check

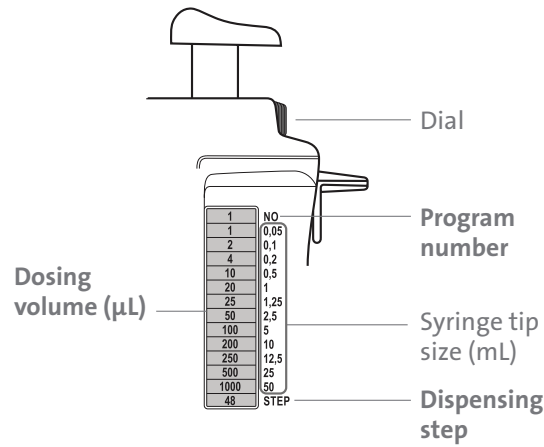

**Example:**  
Program number 1 (NO) dispenses exactly 100 µL in 48 dosing steps (STEP) when a 5 mL syringe tip is used.

## 6. Dispensing

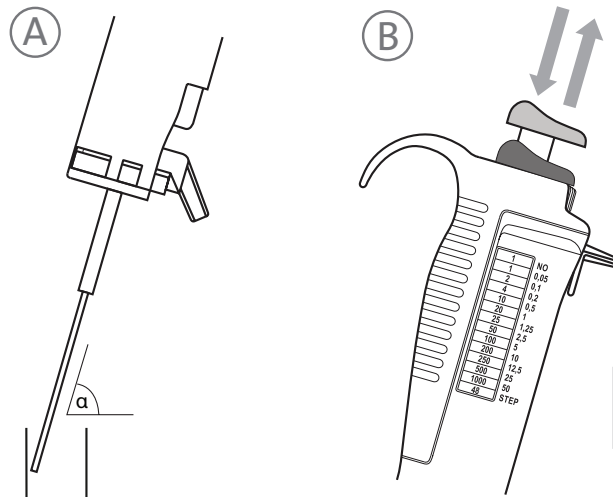

**Important:**  
The first and the last step must be discarded.

For more specific information on claims, visit the Certificates page at [www.corning.com/lifesciences](http://www.corning.com/lifesciences).

**Warranty/Disclaimer:** Unless otherwise specified, all products are for research use only. Not intended for use in diagnostic or therapeutic procedures. Corning Life Sciences makes no claims regarding the performance of these products for clinical or diagnostic applications.

# CORNING

Corning Incorporated  
Life Sciences

836 North St.  
Building 300, Suite 3401  
Tewksbury, MA 01876  
t 800.492.1110  
t 978.442.2200  
f 978.442.2476

[www.corning.com/lifesciences](http://www.corning.com/lifesciences)

For additional product or technical information, visit [www.corning.com/lifesciences](http://www.corning.com/lifesciences) or call 800.492.1110. Outside the United States, call +1.978.442.2200 or contact your local Corning sales office.

For a listing of trademarks, visit [www.corning.com/clstrademarks](http://www.corning.com/clstrademarks). All other trademarks are the property of their respective owners.