



# SZABO SCANDIC

Part of Europa Biosite

## Produktinformation



Forschungsprodukte & Biochemikalien



Zellkultur & Verbrauchsmaterial



Diagnostik & molekulare Diagnostik



Laborgeräte & Service

Weitere Information auf den folgenden Seiten!  
See the following pages for more information!



### Lieferung & Zahlungsart

siehe unsere [Liefer- und Versandbedingungen](#)

### Zuschläge

- Mindermengenzuschlag
- Trockeneiszuschlag
- Gefahrgutzuschlag
- Expressversand

### SZABO-SCANDIC HandelsgmbH

Quellenstraße 110, A-1100 Wien

T. +43(0)1 489 3961-0

F. +43(0)1 489 3961-7

[mail@szabo-scandic.com](mailto:mail@szabo-scandic.com)

[www.szabo-scandic.com](http://www.szabo-scandic.com)

[linkedin.com/company/szaboscandic](https://www.linkedin.com/company/szaboscandic) 



ZYMO RESEARCH

DNA  
Purification  
*Made Simple™*

## ZR-96 DNA Clean-up Kit™

For ultra-pure DNA from PCR, endonuclease digestions, plasmid preparations, etc.

### Highlights

- Quick (20 minute), large-scale recovery of ultra-pure DNA from PCR, endonuclease digestions, plasmid preparations, *etc.*
- **Silicon-A™ Plate** design allows DNA to be eluted at high concentrations into minimal volumes of solvent.
- Eluted DNA is well suited for use in PCR, DNA sequencing, DNA ligation, endonuclease digestion, RNA transcription, radiolabeling, *etc.*
- Omits the use of organic denaturants as well as proteinases.

Catalog Numbers:  
D4017, D4018



Scan with your smart-phone camera to view the online protocol/video.



tech@zymoresearch.com



www.zymoresearch.com



Toll Free: (888) 882-9682

# **Table of Contents**

---

<b>Product Contents</b> .....	<b>01</b>
<b>Specifications</b> .....	<b>02</b>
<b>Product Description</b> .....	<b>03</b>
<b>Protocol</b> .....	<b>04</b>
Buffer Preparation .....	<b>04</b>
Sample Processing .....	<b>04</b>
<b>Appendix</b> .....	<b>05</b>
cDNA Clean-Up .....	<b>05</b>
M13 phage ssDNA Purification .....	<b>05</b>
Isolated DNA stored in DNA/RNA Shield ..	<b>06</b>
RNase A Treatment .....	<b>06</b>
<b>Troubleshooting</b> .....	<b>07</b>
<b>Ordering Information</b> .....	<b>08</b>
<b>Complete Your Cloning Workflow</b> .....	<b>09</b>
<b>Notes</b> .....	<b>10</b>
<b>Guarantee</b> .....	<b>13</b>

# Product Contents

ZR-96 DNA Clean-up Kit™	D4017 (2 x 96 Preps.)	D4018 (4 x 96 Preps.)	Storage Temperature
DNA Binding Buffer	100 ml	2 x 100 ml	Room Temp.
DNA Wash Buffer <sup>1</sup>	24 ml	48 ml	Room Temp.
Silicon-A™ Plate	2	4	Room Temp.
Collection Plate	2	4	Room Temp.
Elution Plate	2	4	Room Temp.
Instruction Manual	1	1	-

---

<sup>1</sup> Ethanol must be added prior to use as indicated on **DNA Wash Buffer** label

# Specifications

- **DNA Purity** – High-quality, purified DNA is eluted with water and is especially well suited for sequencing, ligation reactions, and restriction endonuclease digestions.
- **DNA Size Limits** – From 75 bp to 23 kb.
- **DNA Recovery** – Typically, up to 5 µg total DNA can be eluted into as little as 30-40 µl water per sample. For DNA 75 bp to 10 kb the recovery is 70-90%. For DNA 11 kb to 23 kb the recovery is 50-70%.
- **Sample Sources** – DNA from PCR, restriction endonuclease digestions, plasmid preparations, kinase reactions, *etc.* Suitable for isolated DNA stored in DNA/RNA Shield (page 6).
- **Product Detergent Tolerance** – ≤5% Triton X-100, ≤5% Tween-20, ≤5% Sarkosyl, ≤0.1% SDS.

# Product Description

Zymo Research's **ZR-96 DNA Clean-up Kit™** provides a hassle-free method for rapid, large-scale (96 sample) purification and concentration of high-quality DNA from PCR samples, endonuclease digestions, or "crude" plasmid preparations. Simply add the specially formulated **DNA Binding Buffer** to your samples and transfer to the wells of the supplied **Silicon-A™ Plate**. There is no need for organic denaturants or chloroform. Instead, the product features Fast-Spin column technology to yield high-quality, purified DNA in just minutes. DNA purified using the **ZR-96 DNA Clean-up Kit™** is suitable for nucleotide sequencing, microarray analysis, PCR, nucleotide blotting, and restriction endonuclease digestion procedures.

The **ZR-96 DNA Clean-up Kit™** employs a single-buffer system that allows for efficient DNA adsorption of up to 96 samples onto the matrix of the supplied **Silicon-A™ Plate**. The DNA is washed twice then eluted with a small volume of water into a 96-well **Elution Plate**. The entire DNA purification/concentration procedure typically takes about 20 minutes. The figure below shows a schematic highlighting the **Silicon-A™ Plate** design.

## Improved 96-Well Filter Plate Design

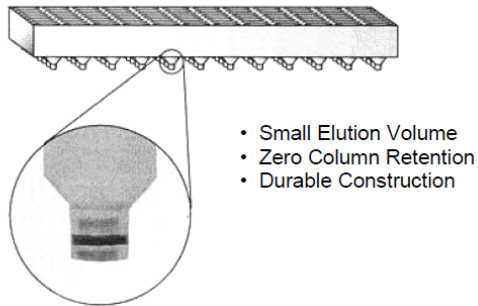

# Protocol

## Buffer Preparation

- ✓ **Before starting:** Add 96 ml 100% ethanol (104 ml 95% ethanol) to the 24 ml **DNA Wash Buffer** concentrate. Add 192 ml 100% ethanol (208 ml 95% ethanol) to the 48 ml **DNA Wash Buffer** concentrate.

## Sample Processing

1. In a 1.5 ml microcentrifuge tube, add 2-7 volumes of **DNA Binding Buffer** to each volume of DNA sample (see table below)<sup>1</sup>. Mix briefly by vortexing.

Application	DNA Binding Buffer : Sample	Example
Plasmid, genomic DNA (>2 kb) <sup>2</sup>	2 : 1	200 µl : 100 µl
PCR product, DNA fragment	5 : 1	500 µl : 100 µl
ssDNA <sup>3</sup> (e.g. cDNA, M13 phage)	7 : 1	700 µl : 100 µl

2. Transfer sample mixtures to the wells of a **Silicon-A™ Plate**<sup>4</sup> mounted onto a **Collection Plate**.
3. Centrifuge at  $\geq 3,000 \times g$  (5,000  $\times g$  max.) for 5 minutes until sample mixtures have been completely filtered. Discard the flow-through.
4. Add 300 µl **DNA Wash Buffer** to each well of the **Silicon-A™ Plate**. Centrifuge at  $\geq 3,000 \times g$  for 5 minutes. Repeat wash step.
5. Add 30-40 µl water<sup>5</sup> directly to the column matrix in each well. Transfer the **Silicon-A™ Plate** onto an **Elution Plate** and centrifuge at  $\geq 3,000 \times g$  for 3 minutes to elute the DNA. Ultra-pure DNA is now ready for use.

<sup>1</sup> Add a minimum of 100 µl of **DNA Binding Buffer** to all samples  $\leq 50$  µl.

<sup>2</sup> For efficient recovery of DNA > 20 kb, use the ZR-96 **Genomic DNA Clean & Concentrator-5 (D4066, D4067)**.

<sup>3</sup> For ssDNA purification, see **Appendix A** on page 5.

<sup>4</sup> The sample capacity of the **Silicon-A Plate™** is 600 µl. Therefore, it may be necessary to load and spin the Plate multiple times if a sample has a volume larger than 600 µl.

<sup>5</sup> Elution of DNA from the column is dependent on pH and temperature. If water is used, make sure the pH is >6.0. Waiting 1 minute prior to elution may improve the yield of large (> 6 kb) DNA. For even larger DNA (> 10 kb), the total yield may be improved by eluting the DNA with 60-70°C water.

# Appendix

## cDNA clean-up

The **DCC**<sup>®</sup> kit can be used to effectively clean and concentrate cDNA (> 500 nt) following reverse transcription (RT) in the presence/absence of fluorescent dyes. Unincorporated free nucleotides and fluorescent derivatives are efficiently removed using the **DCC**<sup>®</sup>, and the recovered cDNA may be used directly for microarray analysis, second-strand cDNA synthesis, or indirect labeling with a fluorescent dye such as NHS ester Cy3 or Cy5.

For clean-up of short cDNAs or ESTs ( $\geq 16$  nt), we recommend the **Oligo Clean & Concentrator** (Cat. Nos. **D4060**, **D4061**).

## Hydrolysis

1. Add 10  $\mu$ l 0.5 M EDTA and 10  $\mu$ l 1 N NaOH to 50  $\mu$ l of RT reaction.

The volumes of EDTA and NaOH should be scaled proportionally depending on the starting volume of the RT reaction.

2. Incubate at 65°C for 15 minutes.

## Clean-up

1. Add 490  $\mu$ l (7 volumes) of **DNA Binding Buffer** to the hydrolysis reaction above. Mix well.

Neutralization (pH) following RNA hydrolysis is not necessary as the **DNA Binding Buffer** will effectively neutralize the NaOH added to the reaction.

2. Continue with Step 2 of the Sample Processing Protocol on page 5.

## M13 phage ssDNA purification

1. Centrifuge phage-infected bacterial culture at 8,000 x g for 1 minute.
2. Transfer 100  $\mu$ l of phage-containing supernatant to a 1.5 ml microcentrifuge tube and add 700  $\mu$ l (7 volumes) of **DNA Binding Buffer**. Mix briefly by vortexing.

Increased supernatant volumes may be processed by proportionally increasing the amount of **DNA Binding Buffer** added to the sample.

3. Continue with Step 2 of the Sample Processing Protocol on page 5.



## Isolated DNA stored in DNA/RNA Shield

*For previously isolated/purified DNA stored in **DNA/RNA Shield**, use the following protocol to recover ultra-pure DNA, ready for downstream applications.*

1. If frozen, thaw samples<sup>1</sup> at room temperature (20-30°C).
2. Add an equal volume of ethanol (95-100%) to the sample and mix well.
3. Continue with Step 2 of the Sample Processing Protocol on page 5.

## RNase A Treatment

Dissolve RNase A (E1008-30), sold separately, in DNase/RNase-free water or TE to a stock concentration of 10 mg/ml.

1. Add enough 10 mg/ml RNase A to the sample for a final concentration of 10-100 µg/mL and mix well.
2. Incubate at room temperature for 15 minutes.
3. Continue with step 1 of the Sample Processing protocol on page 5.

---

<sup>1</sup>Adjust the sample volume to 50 µl (minimum) with **DNA/RNA Shield**.

# Troubleshooting

Problem	Possible Causes and Suggested Solutions
<b>Low Recovery</b>	<p><b>Improperly Prepared/Stored DNA Wash Buffer.</b> Make sure ethanol has been added to the <b>DNA Wash Buffer</b> concentrate. Cap the bottle tightly to prevent evaporation over time.</p> <p><b>Addition of DNA Elution Buffer.</b> Add elution buffer directly to the column matrix, not to the walls of the column. Elution buffer requires contact with the matrix for at least 1 minute for large DNA <math>\geq 10</math> kb.</p> <p><b>Incomplete Elution.</b> DNA elution is dependent on pH, temperature, and time. For large genomic DNA (<math>\geq 50</math> kb), apply heated elution buffer (60-70 °C) to the column and incubate for several minutes prior to elution. Sequential elutions may be performed for quantitatively higher recovery but lower final DNA concentration. This is recommended for DNA <math>\geq 10</math> kb.</p>
<b>Low <math>A_{260}/A_{230}</math> ratio</b>	<p><b>Column tip contaminated.</b> When removing the column from the collection tube, be careful that the tip of the column does not come into contact with the flowthrough. Trace amounts of salt from the flowthrough can contaminate a sample resulting in a low <math>A_{260}/A_{230}</math> ratio. Ethanol contamination from the flowthrough can also interfere with DNA elution. Zymo-Spin™ columns are designed for complete elution with no buffer retention or carryover.</p>
<b>Following Clean-up with DCC®, Multiple Bands Appear in an Agarose Gel</b>	<p><b>Acidification of DNA Loading Dye.</b> Most loading dyes do not contain EDTA and will acidify (<math>\text{pH} \leq 4</math>) over time due to some microbial growth. This low pH is enough to cause DNA degradation. Therefore, if water is used to elute the DNA, 6X Loading Dye containing 1 mM EDTA is recommended.</p>

# Ordering Information

Product Description	Catalog No.	Size
<b>DNA Clean &amp; Concentrator®-5</b> (for purification of up to 5 µg DNA per prep.)	D4003T (uncapped) D4003 (uncapped) D4004 (uncapped)	10 Preps. 50 Preps. 200 Preps.
	D4013 (capped) D4014 (capped)	50 Preps. 200 Preps.
<b>ZR-96 DNA Clean-Up Kit®</b> (for 96-well purification of up to 5 µg DNA per well)	D4017 D4018	2 x 96 Preps. 4 x 96 Preps.
<b>DNA Clean &amp; Concentrator®-25</b> (for purification of up to 25 µg DNA per prep.)	D4005 (uncapped) D4006 (uncapped)	50 Preps. 200 Preps.
	D4033 (capped) D4034 (capped)	50 Preps. 200 Preps.
<b>DNA Clean &amp; Concentrator®-100</b> (for purification of up to 100 µg DNA per prep.)	D4029 D4030	25 Preps. 50 Preps.
<b>DNA Clean &amp; Concentrator®-500</b> (for purification of up to 500 µg DNA per prep.)	D4031 D4032	10 Preps. 20 Preps.
<b>Genomic DNA Clean &amp; Concentrator®</b> (for purification of up to 10 µg genomic DNA per prep.)	D4010 D4011	25 Preps. 100 Preps.

Individual Kit Components	Catalog No.	Amount
<b>DNA Binding Buffer</b>	D4003-1-L	50 ml
	D4004-1-L	100 ml
<b>DNA Wash Buffer</b> (concentrate)	D4003-2-24	24 ml
	D4003-2-48	48 ml
<b>Silicon-A™ Plate</b>	C2001	2 Plates
<b>Collection Plate</b>	C2002	2 Plates
<b>Elution Plate</b>	C2003	2 Plates

# Complete Your Cloning Workflow

## ✓ Transfection-grade plasmid DNA from a miniprep

ZymoPURE™ Plasmid Miniprep	Size	Catalog No.
ZymoPURE™ Plasmid Miniprep Kit	10 Preps. 50 Preps. 100 Preps. 400 Preps. 800 Preps.	D4208T D4209 D4210 D4211 D4212

## ✓ 20 Minute Endotoxin-Free Midi & Maxipreps

ZymoPURE™ II Plasmid Prep Kits	Size	Catalog No.
ZymoPURE™ II Plasmid Midiprep Kit	25 Preps. 50 Preps.	D4200 D4201
ZymoPURE™ II Plasmid Maxiprep Kit	10 Preps. 20 Preps.	D4202 D4203
ZymoPURE™ II Plasmid Gigaprep Kit	5 Preps.	D4204

## ✓ Simple 20 second High Efficiency Transformations

<i>Mix &amp; Go!</i> Competent Cells	Size	Catalog No.
DH5α	10 x 100 µl aliquots 96 x 50 µl aliquots 96 x 50 µl aliquots PCR Plate	T3007 T3009 T3010
Zymo10B	10 x 100 µl aliquots 96 x 50 µl aliquots	T3019 T3020
JM109	10 x 100 µl aliquots 96 x 50 µl aliquots	T3003 T3005
HB101	10 x 100 µl aliquots 96 x 50 µl aliquots	T3011 T3013
TG1	10 x 100 µl aliquots	T3017

## ✓ Recover ultra-pure highly concentrated DNA from PCR & other sources

DNA Clean & Concentrator™	Size	Catalog No.
DNA Clean & Concentrator™-5	50 Preps. 200 Preps.	D4003 D4004
ZR-96 DNA Clean-Up Kit™	2 x 96 Preps. 4 x 96 Preps.	D4017 D4018

## ✓ Rapid extraction of ultra-pure DNA from agarose gels

Zymoclean Gel DNA Recovery™	Size	Catalog No.
Zymoclean™ Gel DNA Recovery Kit	50 Preps. 200 Preps.	D4001 D4002









**100% satisfaction guarantee on all Zymo Research products,  
or your money back.**

Zymo Research is committed to simplifying your research with quality products and services. If you are dissatisfied with this product for any reason, please call 1(888) 882-9682.

---

Integrity of kit components is guaranteed for up to one year from date of purchase. Reagents are routinely tested on a lot-to-lot basis to ensure they provide the highest performance and reliability.

This product is for research use only and should only be used by trained professionals. It is not for use in diagnostic procedures. Some reagents included with this kit are irritants. Wear protective gloves and eye protection. Follow the safety guidelines and rules enacted by your research institution or facility.

™ Trademarks of Zymo Research Corporation





ZYMO RESEARCH

The **BEAUTY** of **SCIENCE** is to Make Things **SIMPLE**®



[tech@zymoresearch.com](mailto:tech@zymoresearch.com)



[www.zymoresearch.com](http://www.zymoresearch.com)



Toll Free: (888) 882-9682